

STORMWATER MANAGEMENT ORDINANCE

ORDINANCE NO. 2022-1

CITY OF HAZLETON

LUZERNE COUNTY, PENNSYLVANIA

Adopted at a Public Meeting Held on
February 8, 2022

Article I - General Provisions

Section 101.	Short Title
Section 102.	Statement of Findings
Section 103.	Purpose
Section 104.	Statutory Authority
Section 105.	Applicability
Section 106.	Repealer
Section 107.	Severability
Section 108.	Compatibility with Other Requirements
Section 109.	Erroneous Permit
Section 110.	Waivers

Article II - Definitions

Article III - Stormwater Management Standards

Section 301.	General Requirements
Section 302.	Exemptions
Section 303.	Volume Controls
Section 304.	Rate Controls

Article IV - Stormwater Management (SWM) Site Plan Requirements

Section 401.	Plan Requirements
Section 402.	Plan Submission
Section 403.	Plan Review
Section 404.	Modification of Plans
Section 405.	Resubmission of Disapproved SWM Site Plans
Section 406.	Authorization to Construct and Term of Validity
Section 407.	As-Built Plans, Completion Certificate and Final Inspection

Article V - Operation and Maintenance

Section 501.	Responsibilities of Developers and Landowners
Section 502.	O&M Agreements

Article VI - Fees and Expenses

Section 601.	General
--------------	---------

Article VII - Prohibitions

Section 701.	Prohibited Discharges and Connections
Section 702.	Roof Drains
Section 703.	Alteration of SWM BMPs

Article VIII - Enforcement and Penalties

Section 801.	Right-of-Entry
Section 802.	Inspection
Section 803.	Enforcement
Section 804.	Suspension and Revocation
Section 805.	Penalties

Article IX - References

Appendix A – Operation and Maintenance (O & M) Agreement

Appendix B – Stormwater Management Permit Application

Appendix C.1 – Disconnected Impervious Area (DIA) and Worksheet

Appendix C.2 – Rainspout Disconnection from Sanitary Sewer Systems

Appendix D – Projects Meeting Requirements in Section 303 Subsection B.

Appendix E – Stormwater Management for Small Projects

Appendix F.1 – Stormwater Management District Maps

Appendix F.2 – Hydrologic Soil Group (HSG) Map

ARTICLE I - GENERAL PROVISIONS

Section 101. Short Title

This Ordinance shall be known and may be cited as the “City of Hazleton Storm Water Management Ordinance” and supersede in entirety *Ordinance 2007-11 “City of Hazleton Storm Water Management Ordinance.”*

Section 102. Statement of Findings

The governing body of the City of Hazleton finds that:

- A. Inadequate management of accelerated runoff of stormwater resulting from development throughout a watershed increases runoff volumes, flows and velocities, contributes to erosion and sedimentation, overtaxes the carrying capacity of streams and storm sewers, greatly increases the cost of public facilities to carry and control stormwater, undermines flood plain management and flood control efforts in downstream communities, reduces groundwater recharge, threatens public health and safety, and increases nonpoint source pollution of water resources.
- B. A comprehensive program of stormwater management (SWM), including reasonable regulation of development and activities causing accelerated runoff, is fundamental to the public health, safety, and welfare and the protection of people of the Commonwealth, their resources, and the environment.
- C. Stormwater is an important water resource that provides groundwater recharge for water supplies and supports the base flow of streams, which also protects and maintains surface water quality.
- D. The use of green infrastructure and low impact development (LID) are intended to address the root cause of water quality impairment by using systems and practices which use or mimic natural processes to: 1) infiltrate and recharge, 2) evapotranspire, and/or 3) harvest and use precipitation near where it falls to earth. Green infrastructure practices and LID contribute to the restoration or maintenance of pre-development hydrology.
- E. Federal and state regulations require certain municipalities to implement a program of stormwater controls. These municipalities are required to obtain a permit for stormwater discharges from their separate storm sewer systems under the National Pollutant Discharge Elimination System (NPDES) program.

Section 103. Purpose

The purpose of this Ordinance is to promote health, safety, and welfare within the City and its watershed by minimizing the harms and maximizing the benefits described in Section 102 of this Ordinance, through provisions designed to:

- A. Meet legal water quality requirements under state law, including regulations at 25 Pa. Code 93 to protect, maintain, reclaim, and restore the existing and designated uses of the waters of this Commonwealth.
- B. Preserve natural drainage systems.
- C. Manage stormwater runoff close to the source, reduce runoff volumes and mimic predevelopment hydrology.
- D. Provide procedures and performance standards for stormwater planning and management.
- E. Maintain groundwater recharge to prevent degradation of surface and groundwater quality and to otherwise protect water resources.
- F. Prevent scour and erosion of stream banks and streambeds.
- G. Provide proper operation and maintenance of all stormwater best management practices (BMP) that are implemented within the City.
- H. Provide standards to meet NPDES permit requirements.

Section 104. Statutory Authority

- A. Primary Authority:

The City is empowered to regulate these activities by the authority of the Act of October 4, 1978, P.L. 864 (Act 167), 32 P.S. Section 680.1, et seq., as amended, the “Storm Water Management Act”, Third Class City Code and City of Hazleton Code, Chapter 4, Article II, Section 4-3, Legislative Power.

- B. Secondary Authority:

The City also is empowered to regulate land use activities that affect runoff by the authority of the Act of July 31, 1968, P.L. 805, No. 247, The Pennsylvania Municipalities Planning Code, as amended.

Section 105. Applicability

All regulated activities and all activities that may affect stormwater runoff, including land development and earth disturbance activity, are subject to regulation by this Ordinance.

Pennsylvania Department of Transportation (PennDOT) roadway projects will perform stormwater management consistent with Publication 13M (Design Manual-2) Chapter 13.6 Antidegradation and Post Construction Stormwater Management Policy.

Section 106. Repealer

Any other ordinance provision(s) or regulation of the City inconsistent with any of the provisions of this Ordinance is hereby repealed to the extent of the inconsistency only.

Section 107. Severability

In the event that a court of competent jurisdiction declares any section or provision of this Ordinance invalid, such decision shall not affect the validity of any of the remaining provisions of this Ordinance.

Section 108. Compatibility with Other Requirements

Approvals issued and actions taken under this Ordinance do not relieve the applicant of the responsibility to secure required permits or approvals for activities regulated by any other code, law, regulation, or ordinance.

The Planning Commission of the City of Hazleton administers the Subdivision and Land Development Ordinance referenced in this Ordinance.

The standards and criteria in this Ordinance supersede the standards and criteria in the previously enacted Luzerne County Storm Water Management Ordinance.

Section 109. Erroneous Permit

Any permit or authorization issued or approved based on false, misleading or erroneous information provided by an applicant is void without the necessity of any proceedings for revocation. Any work undertaken or use established pursuant to such permit or other authorization is unlawful. No action may be taken by a board, agency or employee of the City purporting to validate such a violation.

Section 110. Waivers

- A. If the City determines that any requirement under this Ordinance cannot be achieved for a particular regulated activity, the City may, after an evaluation of

alternatives, approve measures other than those in this Ordinance, subject to Section 110, paragraphs B and C.

- B. Waivers or modifications of the requirements of this Ordinance may be approved by the City if enforcement will exact undue hardship because of peculiar conditions pertaining to the land in question, provided that the modifications will not be contrary to the public interest and that the purpose of the Ordinance is preserved. Cost or financial burden shall not be considered a hardship. Modification may be considered if an alternative standard or approach will provide equal or better achievement of the purpose of the Ordinance. A request for modifications shall be in writing and accompany the Stormwater Management Site Plan submission. The request shall provide the facts on which the request is based, the provision(s) of the Ordinance involved and the proposed modification.
- C. No waiver or modification of any regulated stormwater activity involving earth disturbance greater than or equal to one acre may be granted by the City unless that action is approved in advance by the Department of Environmental Protection (DEP) or the delegated county conservation district.

ARTICLE II - DEFINITIONS

For the purposes of this Ordinance, certain terms and words used herein shall be interpreted as follows:

- A. Words used in the present tense include the future tense; the singular number includes the plural, and the plural number includes the singular; words of masculine gender include feminine gender; and words of feminine gender include masculine gender.
- B. The word “includes” or “including” shall not limit the term to the specific example but is intended to extend its meaning to all other instances of like kind and character.
- C. The words “shall” and “must” are mandatory; the words “may” and “should” are permissive.

Agricultural Activity - Activities associated with agriculture such as agricultural cultivation, agricultural operation, and animal heavy use areas. This includes the work of producing crops including tillage, land clearing, plowing, disking, harrowing, planting, harvesting crops or pasturing and raising of livestock and installation of conservation measures. Construction of new buildings or impervious area is not considered an agricultural activity.

Applicant - A landowner, developer, or other person who has filed an application to the City for approval to engage in any regulated activity at a project site in the City.

Best Management Practice (BMP) - Activities, facilities, designs, measures, or procedures used to manage stormwater impacts from regulated activities, to meet state water quality requirements, to promote groundwater recharge, and to otherwise meet the purposes of this Ordinance. Stormwater BMPs are commonly grouped into one of two broad categories or measures: “structural” or “nonstructural.” In this Ordinance, nonstructural BMPs or measures refer to operational and/or behavior-related practices that attempt to minimize the contact of pollutants with stormwater runoff whereas structural BMPs or measures are those that consist of a physical device or practice that is installed to capture and treat stormwater runoff. Structural BMPs include, but are not limited to, a wide variety of practices and devices, from large-scale retention ponds and constructed wetlands, to small-scale underground treatment systems, infiltration facilities, filter strips, low impact design, bioretention, wet ponds, permeable paving, grassed swales, riparian or forested buffers, sand filters, detention basins, and manufactured devices. Structural stormwater BMPs are permanent appurtenances to the project site.

Capture - The process of collecting runoff to be managed by a stormwater BMP.

Conservation District - A conservation district, as defined in Section 3(c) of the Conservation District Law (3 P. S. § 851(c)) that has the authority under a delegation

agreement executed with DEP to administer and enforce all or a portion of the regulations promulgated under 25 Pa. Code 102; refers to the Luzerne Conservation District unless otherwise noted.

Design Storm - The magnitude and temporal distribution of precipitation from a storm event measured in probability of occurrence (e.g., a 5-year storm) and duration (e.g., 24 hours) used in the design and evaluation of stormwater management systems. Also see Return Period.

Detention Volume - The volume of runoff that is captured and released into the waters of this Commonwealth at a controlled rate.

DEP - The Pennsylvania Department of Environmental Protection.

Development, Land - See “Land Development”.

Development, Site - Any human-induced change to improved or unimproved real estate, whether public or private, including, but not limited to, land development, construction, installation, or expansion of a building or other structure, land division, street construction, drilling, and site alteration such as embankments, dredging, grubbing, grading, paving, parking or storage facilities, excavation, filling, stockpiling, or clearing.

Disconnected Impervious Area (DIA) - An impervious or impermeable surface that is disconnected from any stormwater drainage or conveyance system and is redirected or directed to a pervious area, which allows for infiltration, filtration, and increased time of concentration as specified in Appendix B, Disconnected Impervious Area.

Disturbed Area - An unstabilized land area where an earth disturbance activity is occurring or has occurred.

Earth Disturbance Activity - A construction or other human activity which disturbs the surface of the land, including, but not limited to: clearing and grubbing; grading; excavations; embankments; road maintenance; building construction; and the moving, depositing, stockpiling, or storing of soil, rock, or earth materials.

Erosion - The natural process by which the surface of the land is worn away by water, wind, or chemical action.

Existing Condition - The dominant land cover during the 5-year period immediately preceding a proposed regulated activity.

FEMA - Federal Emergency Management Agency.

Floodplain - Any land area susceptible to inundation by water from any natural source or delineated by applicable FEMA maps and studies as being a special flood hazard area. Also includes areas that comprise Group 13 Soils, as listed in Appendix A of the

Pennsylvania DEP Technical Manual for Sewage Enforcement Officers (as amended or replaced from time to time by DEP).

Floodway - The channel of the watercourse and those portions of the adjoining floodplains that are reasonably required to carry and discharge the 100-year flood. Unless otherwise specified, the boundary of the floodway is as indicated on maps and flood insurance studies provided by FEMA. In an area where no FEMA maps or studies have defined the boundary of the 100-year floodway, it is assumed, absent evidence to the contrary, that the floodway extends from the stream to 50 feet from the top of the bank of the stream.

Forest Management/Timber Operations - Planning and activities necessary for the management of forestland. These include conducting a timber inventory, preparation of forest management plans, silvicultural treatment, cutting budgets, logging road design and construction, timber harvesting, site preparation, and reforestation.

Geotextile - A porous fabric manufactured from synthetic fiber that is used to provide separation between different types of media (i.e., between soil and stone).

Gravel (Crushed Stone) - Considered to be impervious when the intended use of the stone is for transportation purposes, parking areas, construction areas, trails, or if the gravel is compacted at any time during or after its placement; landscaping stone is not considered as impervious area.

Green Infrastructure – Systems and practices that use or mimic natural processes to infiltrate, evapotranspire, or reuse stormwater on the site where it is generated.

Hotspot - Areas where land use or activities generate highly contaminated runoff, with concentrations of pollutants that are higher than those that are typically found in stormwater (e.g., vehicle salvage yards and recycling facilities, vehicle fueling stations, fleet storage areas, vehicle equipment and cleaning facilities, and vehicle service and maintenance facilities).

Hydrologic Soil Group (HSG) - Infiltration rates of soils vary widely and are affected by subsurface permeability as well as surface intake rates. Soils are classified into four HSGs (A, B, C, and D) according to their minimum infiltration rate, which is obtained for bare soil after prolonged wetting. The NRCS defines the four groups and provides a list of most of the soils in the United States and their group classification. The soils in the area of the development site may be identified from a soil survey report that can be obtained from local NRCS offices or conservation district offices. Soils become less pervious as the HSG varies from A to D (NRCS ^{3,4}).

Impervious Surface (Impervious Area) - A surface that prevents the infiltration of water into the ground. Impervious surfaces include, but are not limited to, streets, sidewalks, pavements, parking lots, driveways, roofs, stone patios. See definition of “Gravel (Crushed Stone)” for when gravel classifies as impervious area.

Infiltration - Movement of surface water into the soil, where it is absorbed by plant roots, evaporated into the atmosphere, or percolated downward to recharge groundwater.

Karst - A type of topography or landscape characterized by surface depressions, sinkholes, rock pinnacles/uneven bedrock surface, underground drainage, and caves. Karst is formed on carbonate rocks, such as limestone or dolomite.

Land Development (Development) - Inclusive of any or all of the following meanings: (i) the improvement of one lot or two or more contiguous lots, tracts, or parcels of land for any purpose involving (a) a group of two or more buildings or (b) the division or allocation of land or space between or among two or more existing or prospective occupants by means of, or for the purpose of streets, common areas, leaseholds, condominiums, building groups, or other features; (ii) any subdivision of land; (iii) development in accordance with Section 503(1.1) of the PA Municipalities Planning Code.

Low Impact Development (LID)- A land development and construction approach that uses various land planning, design practices, and technologies to simultaneously conserve and protect natural resource systems, while allowing for necessary infrastructure improvements associated with land development. LID utilizes design techniques that infiltrate, filter, evaporate, and store runoff close to its source. Rather than rely on costly large-scale conveyance and treatment systems, LID addresses stormwater through a variety of small, cost-effective landscape features located on-site.

Municipality – City of Hazleton, Luzerne County, Pennsylvania.

NRCS - USDA Natural Resources Conservation Service (previously SCS).

Peak Discharge - The maximum rate of stormwater runoff from a specific storm event.

Pervious Area - Any area not defined as impervious.

Project Site - The specific area of land where any regulated activities in the City are planned, conducted, or maintained.

Qualified Professional - Any person licensed by the Pennsylvania Department of State or otherwise qualified by law to perform the work required by the Ordinance.

Redevelopment - Any development that requires demolition or removal of existing structures or impervious surfaces at a site and replacement with new impervious surfaces. Maintenance activities such as top-layer grinding and re-paving are not considered to be redevelopment. Interior remodeling projects and tenant improvements are also not considered to be redevelopment.

Regulated Activities - Any earth disturbance activities or any activities that involve the alteration or development of land in a manner that may affect stormwater runoff.

Regulated Earth Disturbance Activity - Activity involving earth disturbance subject to regulation under 25 Pa. Code 92, 25 Pa. Code 102, or the Clean Streams Law.

Retention Volume/Removed Runoff - The volume of runoff that is captured and not released directly into the surface waters of this Commonwealth during or after a storm event.

Return Period - The average interval, in years, within which a storm event of a given magnitude can be expected to occur one time. For example, the 25-year return period rainfall would be expected to occur on average once every 25 years; or stated in another way, the probability of a 25-year storm occurring in any one year is 0.04 (i.e., a 4% chance).

Riparian Buffer – A permanent area of trees and shrubs located adjacent to streams, lakes, ponds and wetlands.

Runoff - Any part of precipitation that flows over the land.

Sediment - Soils or other materials transported by surface water as a product of erosion.

State Water Quality Requirements - The regulatory requirements to protect, maintain, reclaim, and restore water quality under Title 25 of the Pennsylvania Code and the Clean Streams Law.

Stormwater - Drainage runoff from the surface of the land resulting from precipitation or snow or ice melt.

Stormwater Management Facility - Any structure, natural or man-made, that, due to its condition, design, or construction, conveys, stores, or otherwise affects stormwater runoff. Typical stormwater management facilities include, but are not limited to: detention and retention basins; open channels; storm sewers; pipes; French drains; underground on-lot seepage pits; and infiltration facilities.

Stormwater Management Plan - The Luzerne County Stormwater Management Plan for managing stormwater runoff adopted by the County of Luzerne as required by the Act of October 4, 1978, P.L. 864, (Act 167), as amended, and known as the “Storm Water Management Act.”

Stormwater Management Best Management Practices - Is abbreviated as **BMPs** or **SWM BMPs** throughout this Ordinance.

Stormwater Management Site Plan - The plan prepared by the developer or his representative indicating how stormwater runoff will be managed at the development site

in accordance with this Ordinance. **Stormwater Management Site Plan** will be designated as **SWM Site Plan** throughout this Ordinance.

Subdivision - As defined in The Pennsylvania Municipalities Planning Code, Act of July 31, 1968, P.L. 805, No. 247.

USDA - United States Department of Agriculture.

Void Ratio - The ratio of the volume of void space to the total volume of the BMP material (void space plus solid material / media providing structural support to create the storage area).

Waters of this Commonwealth - Any and all rivers, streams, creeks, rivulets, impoundments, ditches, watercourses, storm sewers, lakes, dammed water, wetlands, ponds, springs, and all other bodies or channels of conveyance of surface and underground water, or parts thereof, whether natural or artificial, within or on the boundaries of this Commonwealth.

Watershed - Region or area drained by a river, watercourse, or other surface water of this Commonwealth.

Wetland - Areas that are inundated or saturated by surface or groundwater at a frequency and duration sufficient to support, and that under normal circumstances do support, a prevalence of vegetation typically adapted for life in saturated soil conditions, including swamps, marshes, bogs, and similar areas.

ARTICLE III - STORMWATER MANAGEMENT STANDARDS

Section 301. General Requirements

- A. For all regulated activities, submission of the Stormwater Management Permit Application provided in Ordinance Appendix B is **required**.
- B. For all regulated activities, unless preparation of a SWM Site Plan is specifically exempted in Section 302:
 - 1. Preparation and implementation of an approved SWM Site Plan is required.
 - 2. No regulated activities shall commence until the City issues written approval of a SWM Site Plan, which demonstrates compliance with the requirements of this Ordinance.
- C. SWM Site Plans approved by the City, in accordance with Section 406, shall be on site throughout the duration of the regulated activity.
- D. The City may, after consultation with DEP, approve measures for meeting the state water quality requirements other than those in this Ordinance, provided that they meet the minimum requirements of, and do not conflict with, state law including, but not limited to, the Clean Streams Law.
- E. For all regulated earth disturbance activities, erosion and sediment control BMPs shall be designed, implemented, operated, and maintained during the regulated earth disturbance activities (e.g., during construction) to meet the purposes and requirements of this Ordinance and to meet all requirements under Title 25 of the Pennsylvania Code and the Clean Streams Law. Various BMPs and their design standards are listed in the *Erosion and Sediment Pollution Control Program Manual (E&S Manual)*², No. 363-2134-008 (April 15, 2000), as amended and updated.
- F. For all regulated activities, implementation of the volume controls in Section 303 is required, unless otherwise exempted by Section 302.
- G. Impervious areas:
 - 1. The measurement of impervious areas shall include all of the impervious areas in the total proposed development even if development is to take place in stages.
 - 2. For development taking place in stages, the entire development plan must be used in determining conformance with this Ordinance.

3. For projects that add impervious area to a parcel, the total impervious area is subject to the requirements of this Ordinance, except that the volume controls in Section 303 and the peak rate controls of Section 304 do not need to be retrofitted to existing impervious areas that are not being altered by the proposed regulated activity.
 4. For redevelopment projects in which the existing site is disturbed, the entire proposed site is subject to the plan preparation and approval requirements of this Ordinance. Existing conditions are considered to be the existing site prior to disturbance, and 20% of the existing impervious area must be considered as meadow in good condition for all stormwater calculations. For redevelopment projects in which the existing site is already controlled by a stormwater management facility, the requirement to consider 20% of existing impervious area as meadow is waived provided the existing facility meets the water quality, volume, and peak rate standards and criteria of this Ordinance.
- H. Stormwater flows onto adjacent property shall not be created, increased, decreased, relocated, or otherwise altered without written notification of the adjacent property owner(s). Such stormwater flows shall be subject to the requirements of this Ordinance.
- I. All regulated activities shall include such measures as necessary to:
1. Protect health, safety, and property;
 2. Meet the water quality goals of this Ordinance by implementing measures outlined in the *Pennsylvania Stormwater Best Management Practices Manual* (BMP Manual)¹ to:
 - a. Minimize disturbance to floodplains, wetlands, and wooded areas.
 - b. Maintain or extend riparian buffers.
 - c. Avoid erosive flow conditions in natural flow pathways.
 - d. Minimize thermal impacts to waters of this Commonwealth.
 - e. Disconnect impervious surfaces by directing runoff to pervious areas, wherever possible.
 3. Incorporate methods described in the *Pennsylvania Stormwater Best Management Practices Manual* (BMP Manual⁴). If methods other than green infrastructure and LID methods are proposed to achieve the volume and rate controls required under this Ordinance, the SWM Site Plan must include a detailed justification demonstrating that the use of LID and green infrastructure is not practicable..

- J. The design of all facilities over mined or karst areas shall include an evaluation of measures to minimize adverse effects.

- K. Infiltration BMPs should be spread out, made as shallow as practicable, and located to maximize use of natural on-site infiltration features while still meeting the other requirements of this Ordinance.
- L. Storage facilities, to the greatest extent possible and at the discretion of the City Engineer, shall completely drain both the volume control and rate control capacities over a period of time not less than 24 hours and not more than 72 hours from the end of the design storm.
- M. Storage facilities shall incorporate features to maximize the length of the flow path and increase the travel time through the facility.
- N. The design storm volumes to be used in the analysis of peak rates of discharge should be obtained from the Precipitation-Frequency Atlas of the United States, Atlas 14, Volume 2, Version 3.0, U.S. Department of Commerce, National Oceanic and Atmospheric Administration (NOAA), National Weather Service, Hydrometeorological Design Studies Center, Silver Spring, Maryland. NOAA's Atlas 14 can be accessed at: <http://hdsc.nws.noaa.gov/hdsc/pfds/>.⁵
- O. For all regulated activities, SWM BMPs shall be designed, implemented, operated, and maintained to meet the purposes and requirements of this Ordinance and to meet all requirements under Title 25 of the Pennsylvania Code, the Clean Streams Law, and the Storm Water Management Act.
- P. Various BMPs and their design standards are listed in the BMP Manual¹.

Section 302. Exemptions

- A. Regulated activities that create impervious areas or earth disturbance shall adhere to Table III.1 to meet the requirements of this Ordinance. The larger of the two areas determines the applicable requirements of this Ordinance (i.e. if only 500 sq. ft. of impervious area is proposed, but 15,000 sq. ft. of earth disturbance, the requirements follow row 3 of Table III.1).

Table III.1. Stormwater Management Requirements and Exemptions.

Proposed Impervious Area (sq. ft.)	Proposed Total Earth Disturbance (sq. ft.)	Ordinance Exemptions	Stormwater Management Requirements	What is required to submit to municipality?*
< 1,000	< 5,000	Section 303, Section 304, and Article IV of this Ordinance	Ensure Section 301. General Requirements are met	N/A
1,000 to 5,000	5,000 to 10,000	Section 303, Section 304, and Article IV of this Ordinance	Disconnected Impervious Area (DIA) as in Ordinance Appendix C.1	Ordinance Appendix C.1 Worksheet and Sketch (or equivalent)
			OR	OR
5,000 to 10,000	10,000 to 20,000	Section 304 and Article IV of this Ordinance	Capture and control first 1 inch of runoff over proposed impervious areas as in Ordinance Appendix E	Ordinance Appendix E Worksheet and Sketch (or equivalent)
			Capture and permanently remove the first 2 inches of runoff over proposed impervious areas as in Section 303 B. of this Ordinance	Ordinance Appendix D Worksheet and Sketch (or equivalent)
> 10,000	> 20,000	None	All requirements of this Ordinance	SWM Site Plan

*In addition to the Stormwater Management Permit Application provided in Ordinance Appendix B

- B. Agricultural activity is exempt from the rate control and SWM Site Plan preparation requirements of this Ordinance provided the activities are performed according to the requirements of 25 Pa. Code 102.
- C. Forest management and timber operations are exempt from the rate control and SWM Site Plan preparation requirements of this Ordinance provided the activities are performed according to the requirements of 25 Pa. Code 102.
- D. Exemptions from any provisions of this Ordinance shall not relieve the applicant from the requirements in Sections 301.A. through P.
- E. The City may deny or revoke any exemption pursuant to this Section at any time for any project that the City believes may pose a threat to public health and safety or the environment.

Section 303. Volume Controls

The green infrastructure and low impact development practices provided in the BMP Manual¹ shall be utilized for all regulated activities to the maximum extent practicable. Water volume controls shall be implemented using the *Design Storm Method* in Subsection A or the *Simplified Method* in Subsection B below. For all regulated

activities that require submission of a formal SWM Site Plan, both the *Design Storm Method* and the *Simplified Method* shall be calculated; the larger control volume based on the two calculations shall be controlled. Subsection C below provides requirements for mined or other geologically limiting areas where infiltration shall not occur.

A. The *Design Storm Method* (CG-1 in the BMP Manual¹) is applicable to any size of regulated activity. This method requires detailed modeling based on site conditions.

1. Do not increase the post-development total runoff volume for all storms equal to or less than the 2-year 24-hour duration precipitation.
2. For modeling purposes:
 - a. Existing (predevelopment) non-forested pervious areas must be considered meadow in good condition.
 - b. 20% of existing impervious area, when present, shall be considered meadow in good condition in the model for existing conditions.

B. When *Design Storm Method* CG-1 guidelines are not used, the *Simplified Method* (CG-2 in the BMP Manual¹) has been modified to accommodate 2” of permanently removed runoff volume. This method (provided below) is independent of site conditions and should be used if the *Design Storm Method* is not followed. For new impervious surfaces:

1. The first 2 inches of runoff from new impervious surfaces shall be permanently removed from the runoff flow (i.e., it shall not be released into the surface waters of this Commonwealth). Removal options include reuse, evaporation, transpiration, and infiltration.
2. Wherever possible, infiltration facilities should be designed to accommodate infiltration of the entire permanently removed runoff; however, in all cases at least the first 0.5 inch of the permanently removed runoff should be infiltrated.
3. Facilities, to the greatest extent possible and subject to the City Engineer’s discretion, shall be designed to drain the permanently removed runoff volume in a period no less than 24 hours and no greater than 72 hours.
4. Runoff volume in excess of 2 inches shall be safely conveyed to existing stormwater collection systems or streams, in the direction of the existing drainage course.
5. This method is exempt from the requirements of Section 304, Rate Controls.

- C. Before infiltration is proposed on a site, site conditions shall be evaluated by a qualified design professional through subsurface investigation and testing to determine if site conditions are suitable to support proposed infiltration facilities to manage runoff. If it is determined that infiltration is not feasible due to physical constraints of the site, or will adversely impact the environment as demonstrated by the presence of acid mine drainage, sinkhole formation, or other serious environmental issues, then the above volume controls must be achieved through surface BMP mitigation. Reference the BMP Manual¹ for alternative mitigation measures that do not require infiltration.

Section 304. Rate Controls

- A. Areas not covered by a Stormwater Management District Map contained in Appendix F.1 of the Ordinance:

Post-development discharge rates shall not exceed the predevelopment discharge rates for the 1- through 100-year, 24-hour storms. If it is shown that the peak rates of discharge indicated by the post-development analysis are less than or equal to the peak rates of discharge indicated by the predevelopment analysis for 1- through 100-year, 24-hour storms, then the requirements of this section have been met. Otherwise, the applicant shall provide additional controls as necessary to satisfy the peak rate of discharge requirement.

- B. Areas designated as *District B-2 – Nescopeck Creek Watershed Only*:
 - 1. If a mine reclamation project is proposed, the post-development discharge rates shall not exceed the predevelopment discharge rates for the 1-, 2-, 5-, 10-, 25-, 50-, and 100-year storms. Predevelopment land cover conditions shall be considered forest in good condition.
 - 2. Proposed land development projects shall apply the 60% release rate criterion for the 1-, 2-, 5-, 10-, 25-, 50-, and 100-year storms. This applies to all sites including those that have been previously reclaimed. Predevelopment land cover conditions shall be considered forest in good condition.

Section 305. Riparian Buffers

- A. In order to protect and improve water quality, a Riparian Buffer Easement shall be created and recorded as part of any subdivision or land development that encompasses a Riparian Buffer.
- B. Except as required by Chapter 102, the Riparian Buffer Easement shall be measured to be the greater of the limit of the 100 year floodplain or a minimum of 35 feet from the top of the streambank (on each side).

- C. Minimum Management Requirements for Riparian Buffers:
1. Existing native vegetation shall be protected and maintained within the Riparian Buffer Easement.
 2. Whenever practicable invasive vegetation shall be actively removed and the Riparian Buffer Easement shall be planted with native trees, shrubs and other vegetation to create a diverse native plant community appropriate to the intended ecological context of the site.
- D. The Riparian Buffer Easement shall be enforceable by the city and shall be recorded in the appropriate County Recorder of Deeds Office, so that it shall run with the land and shall limit the use of the property located therein. The easement shall allow for the continued private ownership and shall county toward the minimum lot area as required by Zoning, unless otherwise specified in the City Zoning Ordinance.
- E. Any permitted use within the Riparian Buffer Easement shall be conducted in a manner that will maintain the extent of the existing 100-year floodplain, improve or maintain the stream stability, and preserve and protect the ecological function of the floodplain.
- F. The following conditions shall apply when public and/or private recreation trails are permitted within Riparian Buffers:
1. Trails shall be for non-motorized use only.
 2. Trails shall be designed to have the least impact on native plant species and other sensitive environmental features.
- G. Septic drain fields and sewage disposal systems shall not be permitted within the Riparian Buffer Easement and shall comply with setback requirements established under 25 Pa. Code Chapter 73.

ARTICLE IV - STORMWATER MANAGEMENT (SWM) SITE PLAN REQUIREMENTS

Section 401. Plan Requirements

The following items shall be included in the SWM Site Plan:

- A. Appropriate sections from the City's Subdivision and Land Development Ordinance, and other applicable local ordinances, shall be followed in preparing the SWM Site Plans.
- B. The City shall not approve any SWM Site Plan that is deficient in meeting the requirements of this Ordinance. At its sole discretion and in accordance with this Article, when a SWM Site Plan is found to be deficient, the City may either disapprove the submission or require a resubmission, or in the case of minor deficiencies, the City may accept submission of modifications.
- C. Provisions for permanent access or maintenance easements for all physical SWM BMPs, such as ponds and infiltration structures, as necessary to implement the Operation and Maintenance (O&M) Plan discussed in Item E.9 below.
- D. The following signature block for the City:

 “(City Engineer or designee), on this date (date of signature), has reviewed and hereby certifies that the SWM Site Plan is in compliance with the Municipal Ordinance No. .”
- E. The SWM Site Plan shall provide the following information:
 1. The overall stormwater management concept for the project.
 2. A determination of site conditions in accordance with the BMP Manual¹. A detailed site evaluation shall be completed for projects proposed in mined areas, carbonate geology, or karst topography, and other environmentally sensitive areas, such as brownfields; depending on site conditions, more stringent standards than those in this Ordinance may be imposed at the discretion of the City Engineer.
 3. Stormwater runoff design computations, and documentation as specified in this Ordinance, or as otherwise necessary to demonstrate that the maximum practicable measures have been taken to meet the requirements of this Ordinance, including the recommendations and general requirements in Section Error: Reference source not found; computations are required for all proposed stormwater management facilities.

4. Expected project time schedule.
5. A soil erosion and sediment control plan, where applicable, as prepared for and submitted to the approval authority, and in conformance with 25 Pa. Code 102.
6. The effect of the project (in terms of runoff volumes, water quality, and peak flows) on surrounding properties and aquatic features and on any existing stormwater conveyance system that may be affected by the project.
7. Plan and profile drawings of all SWM BMPs, including drainage structures, pipes, open channels, and swales.
8. SWM Site Plan shall show the locations of existing and proposed on-lot wastewater facilities and water supply wells.
9. The SWM Site Plan shall include an O&M Plan for all existing and proposed physical stormwater management facilities. This plan shall address long-term ownership and responsibilities for O&M as well as schedules and costs for O&M activities.
10. The SWM Site Plan shall include the following additional elements:
 - a. Construction details of all proposed stormwater management facilities.
 - b. A stormwater facility design narrative.
 - c. A signature block containing the name, address, and phone number of the individual responsible for the operation and maintenance plan.
 - d. A drainage area map with time of concentration paths shown.
 - e. Existing contour intervals of two feet.
 - f. All existing features on the property and within 50 feet of property.
 - g. Floodplain and floodway limits.
 - h. Proposed structures and proposed grades.
 - i. Soil boundary lines and descriptions.
 - j. Date of submission, north arrow, graphic scale, call before you dig note and reference number, location map, name of development, name and address of property owner, and individual preparing the SWM Site Plan.
 - k. Existing and proposed easements.
 - l. Statement signed by landowner stating that they cannot alter any stormwater management facility without prior permission of the City.
11. A justification must be included in the SWM Site Plan if BMPs other than green infrastructure methods and LID practices are proposed to achieve the volume, rate and water quality controls under this Ordinance.

Section 402. Plan Submission

- A. _____ Five (5) copies of the SWM Site Plan shall be submitted to the City of Hazleton Planning Commission for distribution as follows:
1. _____ Two (2) copies to the City of Hazleton Planning Commission
 2. _____ One (1) copy to the City Engineer.
 3. _____ One (1) copy to the County Conservation District.
 4. _____ One (1) copy to the County Planning Commission/Office.
- B. Additional copies shall be submitted as requested by the City or DEP.

Section 403. Plan Review

- A. The SWM Site Plan shall be reviewed by the City Engineer for consistency with the provisions of this Ordinance. After review, the City Engineer shall provide a written recommendation for the City approval or disapproval of the SWM Site Plan. If it is recommended to disapprove the SWM Site Plan, the City Engineer shall state the reasons for the disapproval in writing. The City Engineer also may recommend approval of the SWM Site Plan with conditions and, if so, shall provide the acceptable conditions for approval in writing. The SWM Site Plan review and recommendations shall be completed within the time allowed by the Municipalities Planning Code for reviewing subdivision plans.
- B. The City shall notify the applicant in writing within 45 days whether the SWM Site Plan is approved or disapproved. If the SWM Site Plan involves a Subdivision and Land Development Plan, the notification period is 90 days. If a longer notification period is provided by other statute, regulation, or ordinance, the applicant will be so notified by the City. If the City disapproves the SWM Site Plan, the City shall cite the reasons for disapproval in writing.
- C. For any SWM Site Plan that proposed to use any BMPs other than green infrastructure and LID practices to achieve the volume and rate controls required under this Ordinance, the City will not approve the SWM Site Plan unless it determines that green infrastructure and LID practices are not practicable.

Section 404. Modification of Plans

A modification to a submitted SWM Site Plan that involves a change in SWM BMPs or techniques, or that involves the relocation or redesign of SWM BMPs, or that is necessary because soil or other conditions are not as stated on the SWM Site Plan as determined by the City shall require a resubmission of the modified SWM Site Plan in accordance with this Article.

Section 405. Resubmission of Disapproved SWM Site Plans

A disapproved SWM Site Plan may be resubmitted, with the revisions addressing the City's concerns, to the City in accordance with this Article. The applicable review fee must accompany a resubmission of a disapproved SWM Site Plan.

Section 406. Authorization to Construct and Term of Validity

The City's approval of an SWM Site Plan authorizes the regulated activities contained in the SWM Site Plan for a maximum term of validity of 5 years following the date of approval. The City may specify a term of validity shorter than 5 years in the approval for any specific SWM Site Plan. Terms of validity shall commence on the date the City signs the approval for an SWM Site Plan. If an approved SWM Site Plan is not completed according to Section 407 within the term of validity, then the City may consider the SWM Site Plan disapproved and may revoke any and all permits. SWM Site Plans that are considered disapproved by the City shall be resubmitted in accordance with Section 405 of this Ordinance.

Section 407. As-Built Plans, Completion Certificate, and Final Inspection

- A. The developer shall be responsible for providing as-built plans of all SWM BMPs included in the approved SWM Site Plan. The as-built plans and an explanation of any discrepancies with the construction plans shall be submitted to the City of Hazleton Engineer's office.
- B. The as-built submission shall include a certification of completion signed by a qualified professional verifying that all permanent SWM BMPs have been constructed according to the approved plans and specifications. If any licensed qualified professionals contributed to the construction plans, then a licensed qualified professional must sign the completion certificate.
- C. After receipt of the completion certification by the City of Hazleton, the City Engineer or official designee may conduct a final inspection.

ARTICLE V - OPERATION AND MAINTENANCE

Section 501. Responsibilities of Developers and Landowners

- A. The City shall make the final determination on the continuing maintenance responsibilities prior to final approval of the SWM Site Plan. The City may require a dedication of such facilities as part of the requirements for approval of the SWM Site Plan. Such a requirement is not an indication that the City will accept the facilities. The City reserves the right to accept or reject the ownership and operating responsibility for any portion of the stormwater management controls. If the facility is rejected by the City, provisions shall be made to identify the legal owner.

- B. Three options exist for perpetual ownership and responsibility of stormwater management facilities:
 - 1. The developer retains ownership;
 - 2. A Homeowners Association assumes ownership and responsibility;
 - 3. The facility is dedicated to, and accepted by, the City.

- C. Facilities, areas, or structures used as Stormwater Management BMPs shall be enumerated as permanent real estate appurtenances and recorded as deed restrictions or conservation easements that run with the land in the office of the Recorder of Deeds for Luzerne County within 15 days of approval of the SWM Plan by the City..

- D. The O&M Plan shall be recorded as a restrictive deed covenant that runs with the land.

- E. The City may take enforcement actions against an owner for any failure to satisfy the provisions of this Article.

Section 502. Operation and Maintenance Agreements

- A. Prior to the final approval of the SWM Site Plan, the property owner shall sign and record an Operation and Maintenance (O&M) Agreement (see Appendix A) covering all stormwater control facilities which are to be privately owned.
 - 1. The owner, successor and assigns shall maintain all facilities in accordance with the approved maintenance schedule in the O&M Agreement.
 - 2. The owner shall convey to the city conservation easements to assure access for periodic inspections by the city and maintenance, as necessary.

3. The owner shall keep on file with the city the name, address, and telephone number of the person or company responsible for maintenance activities; in the event of a change, new information shall be submitted by the owner to the city within ten (10) working days of the change.
- B. The owner is responsible for operation and maintenance (O&M) of the SWM BMPs. If the owner fails to adhere to the O&M Agreement, the City may perform the services required and charge the owner appropriate fees. Nonpayment of fees may result in a lien against the property.

Section 503. Performance Guarantee

For SWM Plans that involve subdivision and land development, the applicant shall provide a financial guarantee to the city for the timely installation and proper construction of all stormwater management controls as required by the approved SWM Site Plan and this Ordinance in accordance with the provisions of Sections 509, 510, and 511 of the Pennsylvania Municipalities Planning Code.

ARTICLE VI - FEES AND EXPENSES

Section 601. General

The City may include all costs incurred in the review fee charged to an applicant.

The review fee may include, but not be limited to, costs for the following:

- A. Administrative/clerical processing.
- B. Review of the SWM Site Plan.
- C. Attendance at meetings.
- D. Inspections

The inspection fee includes a single inspection of the installed system. Systems failing the initial inspection will require an additional inspection fee.

Section 602. Fee Schedule

Levels 1, 2 & 3

SWM Application Review	\$100.00
SWM Plan Additional Review fee:	\$50.00

Level 4 & DIA

SWM Application Review	\$300.00
SWM Plan Additional Review fee:	\$150.00

Levels 2, 3, 4 & DIA

SWM Inspection Fee:	\$100.00
SWM Site Re-inspection Fee:	\$100.00

ARTICLE VII - PROHIBITIONS

Section 701. Prohibited Discharges and Connections

- A. Any drain or conveyance, whether on the surface or subsurface, that allows any non-stormwater discharge including sewage, process wastewater, and wash water to enter a regulated small MS4 or to enter the surface waters of this Commonwealth is prohibited.
- B. No person shall allow, or cause to allow, discharges into a regulated small SM4, or discharges into waters of this Commonwealth which are not composed entirely of stormwater, except (1) as provided in Subsection C below and (2) discharges allowed under a state or federal permit.
- C. The following discharges are authorized unless they are determined to be significant contributors to pollution to the waters of this Commonwealth:

- Discharges from firefighting activities	- Flows from riparian habitats and wetlands
- Potable water sources including water line flushing and fire hydrant flushing if such discharges do not contain detectable concentrations of Total Residual Chlorine (TRC)	- Uncontaminated water from foundations or from footing drains
- non-contaminated Irrigation drainage	- Lawn watering and landscape drainage
- non-contaminated Air conditioning condensate and water from geothermal systems	- Dechlorinated swimming pool discharges
- Springs	- Uncontaminated groundwater
- non-contaminated water from crawl space pumps	- Water from individual residential car washing where cleaning agents are not utilized
- Pavement wash waters where spills or leaks of toxic or hazardous materials have not occurred (unless all spill material has been removed) and where detergents are not used	- Routine external building wash down (which does not use detergents or other compounds)

- D. In the event that the City or DEP determines that any of the discharges identified in Subsection C significantly contribute pollutants to a regulated small MS4 or to the waters of this Commonwealth, the City or DEP will notify the responsible person(s) to cease the discharge.

Section 702. Roof Drains

Roof drains and sump pumps shall discharge to infiltration or vegetative BMPs wherever feasible and to the maximum extent practicable satisfy the criteria for DIAs consistent with Appendix C.1. of this Ordinance.

Section 703. Alteration of SWM BMPs

No person shall modify, remove, fill, landscape, or alter any SWM BMPs, facilities, areas, or structures that were installed as a requirement of this Ordinance without the written approval of the City.

ARTICLE VIII - ENFORCEMENT AND PENALTIES

Section 801. Right-of-Entry

Upon presentation of proper credentials, the City of Hazleton personnel or its designated agent may enter at reasonable times upon any property within the City of Hazleton to inspect the condition of the storm water structures and facilities in regard to any aspect regulated by this Ordinance.

Section 802. Inspection

The landowner or the owner's designee (including the City for dedicated and owned facilities) shall inspect SWM BMPs facilities and/or structures installed under this Ordinance according to the following frequencies, at a minimum, to ensure the BMPs, facilities and/or structures continue to function as intended:

1. Annually for the first 5 years.
2. Once every 3 years thereafter.
3. During or immediately after the cessation of a 10-year or greater storm.

Inspections should be conducted during or immediately following precipitation events. A written inspection report shall be created to document each inspection. The inspection report shall contain the date and time of the inspection, the individual(s) who completed the inspection, the location of the BMP, facility or structure inspected, observations on performance, and recommendations for improving performance, if applicable. Inspection reports shall be submitted to the City within 30 days following completion of the inspection.

Section 803. Enforcement

- A. It shall be unlawful for a person to undertake any regulated activity except as provided in an approved SWM Site Plan, unless specifically exempted in Section 302 of this Ordinance.
- B. It shall be unlawful to violate Section 703 of this Ordinance.
- C. Inspections regarding compliance with the SWM Site Plan are a responsibility of the City.

Section 804. Suspensions and Revocation

- A. Any approval or permit issued by the City pursuant to this Ordinance may be suspended or revoked for:
 - 1. Non-compliance with or failure to implement any provision of the approved SWM Site Plan or O&M Agreement.
 - 2. A violation of any provision of this Ordinance or any other applicable law, ordinance, rule, or regulation relating to the Regulated Activity.
 - 3. The creation of any condition or the commission of any act during the Regulated Activity which constitutes or creates a hazard, nuisance, pollution, or endangers the life or property of others.
- B. A suspended approval may be reinstated by the City when:
 - 1. The City has inspected and approved the corrections to the violations that caused the suspension.
 - 2. The City is satisfied that the violation has been corrected.
- C. An approval that has been revoked by the City cannot be reinstated. The applicant may apply for a new approval under the provisions of this Ordinance.
- D. If a violation causes no immediate danger to life, public health, or property, at its sole discretion, the City may provide a limited time period for the owner to correct the violation. In these cases, the City will provide the owner, or the owner's designee, with a written notice of the violation and the time period allowed for the owner to correct the violation. If the owner does not correct the violation within the allowed time period, the City may revoke or suspend any, or all, applicable approvals and permits pertaining to any provision of this Ordinance.

Section 805. Penalties

- A. Anyone violating the provisions of this Ordinance shall be guilty of a summary offense, and upon conviction, shall be subject to a fine of not more than one-thousand (\$1,000.00) for each violation, recoverable with costs, including but not limited to, Court costs and attorney fees. Each day that the violation continues shall be a separate offense and penalties shall be cumulative.
- B. In addition, the City may institute injunctive, mandamus, or any other appropriate action or proceeding at law or in equity for the enforcement of this Ordinance. Any Court of competent jurisdiction shall have the right to issue restraining orders, temporary or permanent injunctions, mandamus, or other appropriate forms of remedy or relief.

Section 806. Appeals

- A. Any person aggrieved by any action of the City or its designee, relevant to the provisions of this Ordinance, may appeal to the City within 30 days of that action.
- B. Any person aggrieved by any decision of the City, its representative or designee, relevant to the provisions of this Ordinance, may appeal to the County Court of Common Pleas in the county where the activity has taken place within thirty (30) days of the City's decision.

ARTICLE IX - REFERENCES

1. Pennsylvania Department of Environmental Protection. No. 363-0300-002 (December 2006), as amended and updated. *Pennsylvania Stormwater Best Management Practices Manual*. Harrisburg, PA.
2. Pennsylvania Department of Environmental Protection. No. 363-2134-008 (April 15, 2000), as amended and updated. *Erosion and Sediment Pollution Control Program Manual*. Harrisburg, PA.
3. U.S. Department of Agriculture, National Resources Conservation Service (NRCS). *National Engineering Handbook*. Part 630: Hydrology, 1969-2001. Originally published as the *National Engineering Handbook*, Section 4: Hydrology. Available from the NRCS online at: <http://www.nrcs.usda.gov/>.
4. U.S. Department of Agriculture, Natural Resources Conservation Service. 1986. *Technical Release 55: Urban Hydrology for Small Watersheds*, 2nd Edition. Washington, D.C.
5. U.S. Department of Commerce, National Oceanic and Atmospheric Administration, National Weather Service, Hydrometeorological Design Studies Center. 2004-2006. *Precipitation-Frequency Atlas of the United States, Atlas 14*, Volume 2, Version 3.0, Silver Spring, Maryland. Internet address: <http://hdsc.nws.noaa.gov/hdsc/pfds/>.

APPENDIX A

**OPERATION AND MAINTENANCE (O&M) AGREEMENT
STORMWATER MANAGEMENT BEST MANAGEMENT PRACTICES (SWM
BMPs)**

THIS AGREEMENT, made and entered into this _____ day of _____, 20____, by and between _____, (hereinafter the “Landowner”), and City of Hazleton, Luzerne County, Pennsylvania, (hereinafter “City”);

WITNESSETH

WHEREAS, the Landowner is the owner of certain real property as recorded by deed in the land records of Luzerne County, Pennsylvania, Deed Book _____ at page _____, (hereinafter “Property”).

WHEREAS, the Landowner is proceeding to build and develop the Property; and

WHEREAS, the SWM BMP O&M Plan approved by the City (hereinafter referred to as the “O&M Plan”) for the property identified herein, which is attached hereto as Appendix A and made part hereof, as approved by the City, provides for management of stormwater within the confines of the Property through the use of BMPs; and

WHEREAS, the City, and the Landowner, his successors and assigns, agree that the health, safety, and welfare of the residents of the City and the protection and maintenance of water quality require that on-site SWM BMPs be constructed and maintained on the Property; and

WHEREAS, the City requires, through the implementation of the SWM Site Plan, that SWM BMPs as required by said Plan and the Municipal Stormwater Management Ordinance be constructed and adequately operated and maintained by the Landowner, successors, and assigns.

NOW, THEREFORE, in consideration of the foregoing promises, the mutual covenants contained herein, and the following terms and conditions, the parties hereto agree as follows:

1. The Landowner shall construct the BMPs in accordance with the plans and specifications identified in the SWM Site Plan.
2. The Landowner shall operate and maintain the BMPs as shown on the SWM Site Plan in good working order in accordance with the specific maintenance requirements noted on the approved O&M Plan.

3. The Landowner hereby grants permission to the City, its authorized agents and employees, to enter upon the property, at reasonable times and upon presentation of proper credentials, to inspect the BMPs whenever necessary. The City shall notify the Landowner prior to entering the property.
4. In the event the Landowner fails to operate and maintain the BMPs per paragraph 2, the City or its representatives may enter upon the Property and take whatever action is deemed necessary to maintain said BMP(s). It is expressly understood and agreed that the City is under no obligation to maintain or repair said facilities, and in no event shall this Agreement be construed to impose any such obligation on the City.
5. In the event the City, pursuant to this Agreement, performs work of any nature, or expends any funds in performance of said work for labor, use of equipment, supplies, materials, and the like, the Landowner shall reimburse the City for all expenses (direct and indirect) incurred within 10 days of receipt of invoice from the City.
6. The intent and purpose of this Agreement is to ensure the proper maintenance of the onsite BMPs by the Landowner; provided, however, that this Agreement shall not be deemed to create or effect any additional liability of any party for damage alleged to result from or be caused by stormwater runoff.
7. The Landowner, its executors, administrators, assigns, and other successors in interests, shall release the City from all damages, accidents, casualties, occurrences, or claims which might arise or be asserted against said employees and representatives from the construction, presence, existence, or maintenance of the BMP(s) by the Landowner or City.
8. The City intends to inspect the BMPs at a minimum of once every three years to ensure their continued functioning.

This Agreement shall be recorded at the Office of the Recorder of Deeds of Luzerne County, Pennsylvania, and shall constitute a covenant running with the Property and/or equitable servitude, and shall be binding on the Landowner, his administrators, executors, assigns, heirs, and any other successors in interests, in perpetuity.

ATTEST:

WITNESS the following signatures and seals:

(SEAL)

For the City of Hazleton:

For the Landowner:

ATTEST:

_____ (City of Hazleton)

County of Luzerne, Pennsylvania

I, _____, a Notary Public in and for the county and state aforesaid, whose commission expires on the _____ day of _____, 20____, do hereby certify that _____ whose name(s) is/are signed to the foregoing Agreement bearing date of the _____ day of _____, 20____, has acknowledged the same before me in my said county and state.

GIVEN UNDER MY HAND THIS _____ day of _____, 20_____.

NOTARY PUBLIC

(SEAL)

APPENDIX B

STORMWATER MANAGEMENT PERMIT APPLICATION

Anyone performing a regulated activity must complete the accompanying Stormwater Management Permit Application, and submit to the City. A regulated activity is defined by this Ordinance as:

Regulated Activity - Any earth disturbance activities or any activities that involve the alteration or development of land in a manner that may affect stormwater runoff.

This includes but is not limited to: the clearing of wooded areas, grading and excavating, placement of pavement (driveways, parking areas, roads), construction of buildings and other structures (homes, sheds, garages, commercial and industrial buildings), and other activities which alter the way stormwater runs off of the landscape. Impervious area is defined by this Ordinance as:

Impervious Surface (Impervious Area) - A surface that prevents the infiltration of water into the ground. Impervious surfaces include, but are not limited to, streets, sidewalks, pavements, parking lots, driveways, roofs, stone patios. See definition of “Gravel (Crushed Stone)” for when gravel classifies as impervious area.

Gravel (Crushed Stone) - Considered to be impervious when the intended use of the stone is for transportation purposes, parking areas, construction areas, trails, or if the gravel is compacted at any time during or after its placement; landscaping stone is not considered as impervious area.

Depending on the amount of impervious area placed and the amount of earth disturbance to the project site, this Ordinance requires different levels of stormwater management, and correspondingly different levels of design and review.

Level 1: Proposed impervious area is less than 1,000 sq. ft. and total earth disturbance is less than 5,000 sq. ft.

Stormwater Management Controls: Ensure that adverse downstream impacts do not occur due to redirecting stormwater flows towards nearby structures.

Submission: Submit the Stormwater Management Permit Application and Project Sketch; the easiest mechanism is to include the application with Building Permits.

Review: Reviewing the application will not likely require a qualified professional.

Level 2: Proposed impervious area is between 1,000 sq. ft. and 5,000 sq. ft. or total earth disturbance is between 5,000 sq. ft. and 10,000 sq. ft.

Stormwater Management Controls: Utilize Disconnected Impervious Area (DIA) for stormwater controls as outlined in Ordinance Appendix C.1; if DIA cannot be achieved, utilize stormwater management controls for small projects as outlined in Ordinance Appendix E.

Submission: Submit the Stormwater Management Permit Application and computations for DIA; the worksheet in this Ordinance Appendix C.1 may be used and submitted as is,

or may be modified as the City sees fit. If DIA cannot be achieved, submit computations for Stormwater Management for Small Projects; the worksheet in this Ordinance Appendix E may be used and submitted as is, or may be modified as the City sees fit; the easiest mechanism is to include the application with Building Permits.

Review: Reviewing the application and computations may require a qualified professional if the person responsible for issuing Building Permits is not comfortable with performing the review.

Level 3: Proposed impervious area is between 5,000 sq. ft. and 10,000 sq. ft. or total earth disturbance is between 10,000 sq. ft. and 20,000 sq. ft.

Stormwater Management Controls: Capture and permanently remove the first 2 inches of runoff over all proposed impervious areas; infiltrate at least the first 0.5 inches.

Submission: Submit the Stormwater Management Permit Application and computations for permanently removing the first 2 inches of runoff over all proposed impervious areas; the worksheet in this Ordinance Appendix D may be used and submitted as is, or may be modified as the City sees fit.

Review: Reviewing the application and computations will most likely require a qualified professional.

Level 4: Proposed impervious area is greater than 10,000 sq. ft. or total earth disturbance is greater than 20,000 sq. ft.

Stormwater Management Controls: All requirements of this Ordinance are applicable, including water quality and volume controls as found in Article III Section 303 and peak rate controls as found in Article III Section 304.

Submission: Submit the Stormwater Management Permit Application and Stormwater Management (SWM) Site Plan as in Article IV of this Ordinance.

Review: Reviewing the application and SWM Site Plan requires a qualified professional.

Following the Stormwater Management Permit Application and accompanying sketch sheet are examples of common smaller projects which do not require the review by a qualified professional (review by a qualified professional is optional). An Alternative Stormwater Management Permit Application is also provided following the examples. Both forms may be modified by the City before one is selected.

STORMWATER MANAGEMENT PERMIT APPLICATION

PROJECT SKETCH

EXAMPLE 1 STORMWATER MANAGEMENT PERMIT APPLICATION

EXAMPLE 1 PROJECT SKETCH

EXAMPLE 2 STORMWATER MANAGEMENT PERMIT APPLICATION

EXAMPLE 2 PROJECT SKETCH – Homeowner opted to utilize the worksheet provided in Appendix C.1 to show stormwater management for DIA.

Applicant Address: Joe Homeowner 123 Site Street Hazleton, PA 18201	Brief Description of Project: Construction of 2,000 sq. ft. (40' x 50') single-family home with 500 sq. ft. driveway (10' x 50') and 800 sq. ft. stone patio (20' x 40'). The back half of the house discharges to rainspouts underground.				
Nearest waterbody: Tributary to Black Creek	No more than 1,000 sq. ft. can discharge to one point on the surface. Number of surface discharge points required: 3				
Total Proposed Impervious Area (A): 3,300 sq. ft. Total Earth Disturbance: 6,000 sq. ft.	Discharge Point 1: Front of Home	Discharge Point 2: Driveway	Discharge Point 3: Patio	Discharge Point 4: N/A	Discharge Point 5: N/A
	Area: 1,000 sq. ft.	Area: 500 sq. ft.	Area: 800 sq. ft.	Area: N/A	Area: N/A
Are rainspouts discharged underground? (Y/N) Yes If yes, contributing impervious area (B): 1,000 sq. ft.	Impervious Path Length: 20 ft	Impervious Path Length: 10 ft	Impervious Path Length: 20 ft	Impervious Path Length: N/A	Impervious Path Length: N/A
	Pervious Path Length: 30 ft	Pervious Path Length: 50 ft	Pervious Path Length: 40 ft	Pervious Path Length: N/A	Pervious Path Length: N/A
Total Impervious Area Discharged on Surface (A) – (B): 3,300 – 1,000 = 2,300 sq. ft.	Pervious Path Slope <10%? (Y/N) Yes	Pervious Path Slope <10%? (Y/N) Yes	Pervious Path Slope <10%? (Y/N) Yes	Pervious Path Slope <10%? (Y/N) N/A	Pervious Path Slope <10%? (Y/N) N/A
HSG Soil Group from Appendix F.2 Hydrologic Soils Group Map (Cannot be “D” Soils): HSG “C”					
Project sketch: <div style="border: 1px solid black; height: 200px; width: 100%;"></div>					

EXAMPLE 3 STORMWATER MANAGEMENT PERMIT APPLICATION

EXAMPLE 3 PROJECT SKETCH – Homeowner opted to utilize the worksheet provided in Appendix C.1 to show stormwater management for DIA.

Applicant Address: Joe Homeowner 123 Site Street Hazleton, PA 18201	Brief Description of Project: Construction of 2,000 sq. ft. (40' x 50') single-family home with 500 sq. ft. driveway (10' x 50') and 800 sq. ft. stone patio (20' x 40'). The back half of the house discharges to rainspouts underground.				
Nearest waterbody: Tributary to Black Creek	No more than 1,000 sq. ft. can discharge to one point on the surface. Number of surface discharge points required: 3				
Total Proposed Impervious Area (A): 3,300 sq. ft. Total Earth Disturbance: 6,000 sq. ft.	Discharge Point 1: Front of Home	Discharge Point 2: Driveway	Discharge Point 3: Patio	Discharge Point 4: N/A	Discharge Point 5: N/A
	Area: 1,000 sq. ft.	Area: 500 sq. ft.	Area: 800 sq. ft.	Area: N/A	Area: N/A
Are rainspouts discharged underground? (Y/N) Yes If yes, contributing impervious area (B): 1,000 sq. ft.	Impervious Path Length: 20 ft	Impervious Path Length: 50 ft	Impervious Path Length: 20 ft	Impervious Path Length: N/A	Impervious Path Length: N/A
	Pervious Path Length: N/A	Pervious Path Length: N/A	Pervious Path Length: 40 ft	Pervious Path Length: N/A	Pervious Path Length: N/A
Total Impervious Area Discharged on Surface (A) – (B): 3,300 – 1,000 = 2,300 sq. ft.	Pervious Path Slope <10%? (Y/N) N/A	Pervious Path Slope <10%? (Y/N) N/A	Pervious Path Slope <10%? (Y/N) Yes	Pervious Path Slope <10%? (Y/N) N/A	Pervious Path Slope <10%? (Y/N) N/A
HSG Soil Group from Appendix F.2 Hydrologic Soils Group Map (Cannot be “D” Soils): HSG “C”					
Project sketch: <div style="border: 1px solid black; height: 200px; width: 100%;"></div>					

APPENDIX C.1

DISCONNECTED IMPERVIOUS AREA (DIA) AND WORKSHEET

When a regulated activity creates impervious areas between 1,000 sq. ft. and 5,000 sq. ft., or total earth disturbance between 5,000 and 10,000 sq. ft., the stormwater management requirements follow Appendix C.1 – Disconnected Impervious Areas (DIAs), of this Ordinance. If site conditions prevent the requirements of Appendix C.1 from being met, then the first 1 inch of runoff shall be captured and controlled in a manner consistent with Appendix E – Stormwater Management for Small Projects, of this Ordinance.

When rooftop or pavement runoff is directed to a pervious area that allows for infiltration, filtration, and increased time of concentration, the contributing rooftop or pavement area may qualify as a Disconnected Impervious Area (DIA). A rooftop or pavement area is considered to be a DIA if it meets the requirements listed below:

- The soil, in proximity of the discharge area, is not designated as hydrologic soil group “D” or equivalent (see Appendix F.2. Hydrologic Soil Group Map);
- The overland flow path (pervious area serving as BMP) from discharge area has a positive slope of 10% or less;
- The length of overland flow path (pervious area serving as BMP) is greater than or equal to the contributing rooftop or pavement length;
- The length of overland flow path (pervious area serving as BMP) is greater than 25 feet.

If the discharge is concentrated at one or more discrete points, no more than 1,000 square feet of impervious area may discharge to any one point. In addition, a gravel strip or other spreading device is required for concentrated discharges. For non-concentrated discharges along the edge of the pavement, this requirement is waived; however, there must be a provision for the establishment of vegetation along the pavement edge and temporary stabilization of the area until vegetation becomes stabilized.

If rainspouts are discharged underground to provide infiltration, the portion of the impervious area draining to those rainspouts is waived from the DIA discharge requirements. Rainspouts discharged underground which are directly connected to a storm sewer system are not waived from the DIA requirements.

Computations for DIA as a BMP must be submitted to the municipality. This worksheet is provided as an example, or may be used for the computations.

Applicant Address:	Brief Description of Project:				
Nearest waterbody:	No more than 1,000 sq. ft. can discharge to one point on the surface. Number of discharge points required:				
Total Proposed Impervious Area (A):	Discharge Point 1	Discharge Point 2	Discharge Point 3	Discharge Point 4	Discharge Point 5
Total Earth Disturbance:	Area:	Area:	Area:	Area:	Area:
Are rainspouts discharged underground? (Y/N)	Impervious Path Length:	Impervious Path Length:	Impervious Path Length:	Impervious Path Length:	Impervious Path Length:
If yes, contributing impervious area (B):	Pervious Path Length:	Pervious Path Length:	Pervious Path Length:	Pervious Path Length:	Pervious Path Length:
Total Impervious Area Discharged on Surface (A) – (B):	Pervious Path Slope <10%? (Y/N)	Pervious Path Slope <10%? (Y/N)	Pervious Path Slope <10%? (Y/N)	Pervious Path Slope <10%? (Y/N)	Pervious Path Slope <10%? (Y/N)
HSG Soil Group from Appendix F.2 Hydrologic Soils Group Map (Cannot be “D” Soils):					
Project sketch:					

Example: Joe Homeowner would like to build a single-family home, with a driveway and backyard stone patio. The home is 2,000 sq. ft., the stone patio is 800 sq. ft., and the asphalt driveway is 500 square feet.

Applicant Address: Joe Homeowner 123 Site Street Hazleton, PA 18201	Brief Description of Project: Construction of 2,000 sq. ft. (40' x 50') single-family home with 500 sq. ft. driveway (10' x 50') and 800 sq. ft. stone patio (20' x 40'). The back half of the house discharges to rainspouts underground.				
Nearest waterbody: Tributary to Black Creek	No more than 1,000 sq. ft. can discharge to one point on the surface. Number of surface discharge points required: 3				
Total Proposed Impervious Area (A): 3,300 sq. ft. Total Earth Disturbance: 6,000 sq. ft.	Discharge Point 1: Front of Home	Discharge Point 2: Driveway	Discharge Point 3: Patio	Discharge Point 4: N/A	Discharge Point 5: N/A
	Area: 1,000 sq. ft.	Area: 500 sq. ft.	Area: 800 sq. ft.	Area: N/A	Area: N/A
Are rainspouts discharged underground? (Y/N) Yes If yes, contributing impervious area (B): 1,000 sq. ft.	Impervious Path Length: 20 ft	Impervious Path Length: 10 ft	Impervious Path Length: 20 ft	Impervious Path Length: N/A	Impervious Path Length: N/A
	Pervious Path Length: 30 ft	Pervious Path Length: 50 ft	Pervious Path Length: 40 ft	Pervious Path Length: N/A	Pervious Path Length: N/A
Total Impervious Area Discharged on Surface (A) – (B): 3,300 – 1,000 = 2,300 sq. ft.	Pervious Path Slope <10%? (Y/N) Yes	Pervious Path Slope <10%? (Y/N) Yes	Pervious Path Slope <10%? (Y/N) Yes	Pervious Path Slope <10%? (Y/N) N/A	Pervious Path Slope <10%? (Y/N) N/A
HSG Soil Group from Appendix F.2 Hydrologic Soils Group Map (Cannot be “D” Soils): HSG “C”					
Project sketch: <div style="border: 1px solid black; height: 200px; width: 100%;"></div>					

APPENDIX C.2

RAINSPOUT DISCONNECTION FROM SANITARY SEWER SYSTEMS REQUIREMENT FOR MUNICIPALITIES

When roofs are being replaced, rainspouts must be disconnected from sanitary sewer systems. The following guidance is provided to enforce this requirement as part of this Ordinance, and is subject to the municipal engineer's discretion. When rainspouts are disconnected from sanitary sewer systems, it must be shown that adverse stormwater impacts are not created downstream.

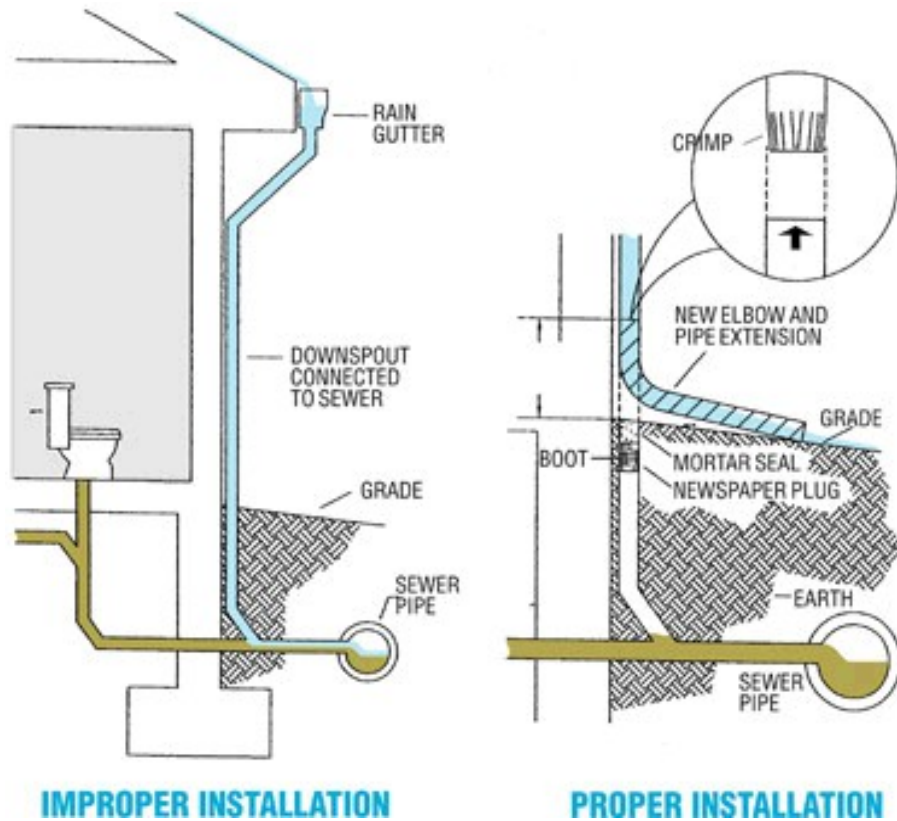

Source of image: www.munciesanitary.org/stormwater-management

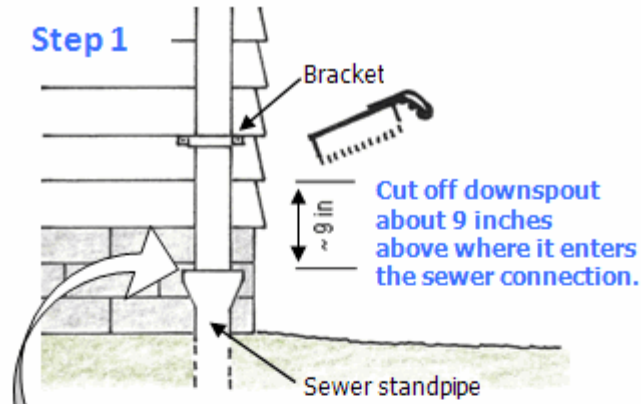

Step 2 Measure and install plug or cap

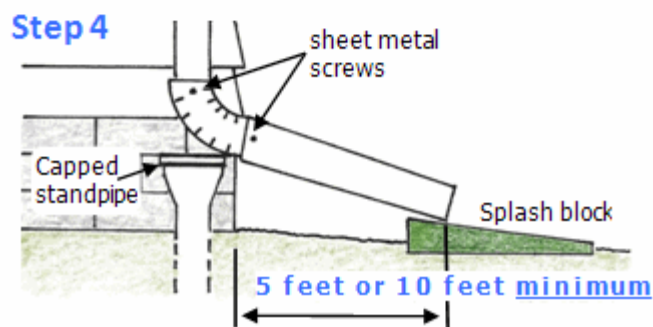
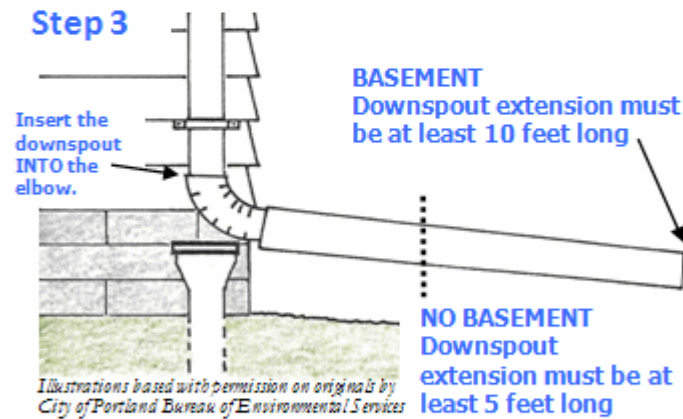
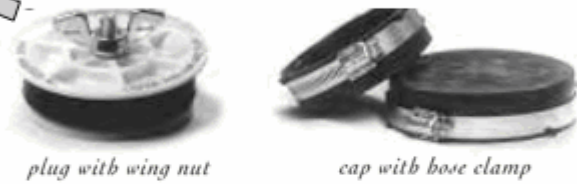

PROJECTS MEETING REQUIREMENTS IN SECTION 303 SUBSECTION B

When a regulated activity creates impervious areas between 5,000 sq. ft. and 10,000 sq. ft., or total earth disturbance between 10,000 and 20,000 sq. ft., the stormwater management requirements follow Section 303 Subsection B of this Ordinance.

Section 303 Subsection B is duplicated below:

- B. When CG-1 guidelines are not used, the *Simplified Method* (CG-2 in the BMP Manual¹) has been modified to accommodate 2" of permanently removed runoff volume. This method (provided below) is independent of site conditions and should be used if the *Design Storm Method* is not followed. For new impervious surfaces:
1. The first 2 inches of runoff from new impervious surfaces shall be permanently removed from the runoff flow (i.e., it shall not be released into the surface waters of this Commonwealth). Removal options include reuse, evaporation, transpiration, and infiltration.
 2. Wherever possible, infiltration facilities should be designed to accommodate infiltration of the entire permanently removed runoff; however, in all cases at least the first 0.5 inch of the permanently removed runoff should be infiltrated.
 3. Facilities, to the greatest extent possible and subject to the Municipal Engineer's discretion, shall be designed to drain the permanently removed runoff volume in a period no less than 24 hours and no greater than 72 hours.
 4. Runoff volume in excess of 2 inches shall be safely conveyed to existing stormwater collection systems or streams, in the direction of the existing drainage course.
 5. This method is exempt from the requirements of Section 304, Rate Controls.

Computations for all stormwater facilities must be submitted to the municipality.
This worksheet is provided as an example, or may be used for the computations.

Applicant Address:	Brief Description of Project:		
Nearest waterbody:	Permanently Removed Volume = (2 inches / 12) x (Impervious Area) =		
Total Proposed Impervious Area:	A Factor of Safety of 2 is applied to the Tested Infiltration Rate. Design Infiltration Rate = Tested Infiltration Rate / 2 =		
Total Earth Disturbance:	Components of the project may be directed to multiple facilities. Number of facilities used:		
Soil Testing Method:	Facility #1	Facility #2	Facility #3
	Component of Project:	Component of Project:	Component of Project:
	Volume Collected:	Volume Collected:	Volume Collected:
Tested Infiltration Rate (in/hr):	Type of Facility:	Type of Facility:	Type of Facility:
	Volume of Facility*:	Volume of Facility*:	Volume of Facility*:
	Area of Facility:	Area of Facility:	Area of Facility:
	Depth of Facility:	Depth of Facility:	Depth of Facility:
Additional Calcs/Notes:	Drawdown Time = Depth of Facility / Design Infiltration Rate =	Drawdown Time = Depth of Facility / Design Infiltration Rate =	Drawdown Time = Depth of Facility / Design Infiltration Rate =
	Loading Ratio = Impervious Area Controlled : Area of Facility =	Loading Ratio = Impervious Area Controlled : Area of Facility =	Loading Ratio = Impervious Area Controlled : Area of Facility =
	Existing Discharge Point (Inlet/Sewer/Stream):	Existing Discharge Point (Inlet/Sewer/Stream):	Existing Discharge Point (Inlet/Sewer/Stream):
	Discharge Method for Runoff in Excess of 2": Capacity**:	Discharge Method for Runoff in Excess of 2": Capacity**:	Discharge Method for Runoff in Excess of 2": Capacity**:
*Infiltration facilities with stone beds: 40% void space, multiply volume in stone portion by 0.4. Calculations:			
**If a grass spillway is used: Capacity (cfs) = 2.5 x Length x Freeboard ^{1.5} **If an orifice structure is used: Capacity (cfs) = 0.6 x Orifice Area x (2 x 32.2 x Flow Depth Above Orifice) ^{0.5} Capacity Calculations:			

Example: A doctor's office is proposed for a site. The building is 5,000 sq. ft. and the parking lot is 3,000 sq. ft.

Applicant Address: Dr. Office 123 Site Street Hazleton, PA 18201	Brief Description of Project: A proposed doctor's office consisting of 5,000 sq. ft. building (50' x 100') and 3,000 sq. ft. parking lot (30' x 100'). The building drains to the back of the property to an infiltration facility, and the parking lot drains to an infiltration facility adjacent the parking lot.		
Nearest waterbody: Trib. to Black Creek	Permanently Removed Volume = (2 inches / 12) x (Impervious Area) = (2 inches / 12) x (8,000 sq. ft.) = 1,333 cu. ft.		
Total Proposed Impervious Area: 8,000 sq. ft.	A Factor of Safety of 2 is applied to the Tested Infiltration Rate. Design Infiltration Rate = Tested Infiltration Rate / 2 = 1 in/hr / 2 = 0.5 in/hr		
Total Earth Disturbance: 12,000 sq. ft.	Components of the project may be directed to multiple facilities. Number of facilities used: 2		
Soil Testing Method: Percolation Test	Facility #1	Facility #2	Facility #3
	Component of Project: Building Volume Collected: 5,000 x 2/12 = 833 cu. ft.	Component of Project: Parking Lot Volume Collected: 3,000 x 2/12 = 500 cu. ft.	Component of Project: N/A Volume Collected: N/A
Tested Infiltration Rate (in/hr): 1 in/hr	Type of Facility: Infiltration Volume of Facility*: 1,133 cu. ft. Area of Facility: 50' x 10' = 500 sq. ft. Depth of Facility: 1 ft. stone + 1.3 ft. = 2.3 ft.	Type of Facility: Infiltration Volume of Facility*: 590 cu. ft. Area of Facility: 30' x 10' = 300 sq. ft. Depth of Facility: ½ ft. stone + 1.3 ft. = 1.8 ft.	Type of Facility: N/A Volume of Facility*: N/A Area of Facility: N/A Depth of Facility: N/A
Additional Calcs/Notes: Facilities have 2:1 horizontal:vertical side slopes. Therefore, actual volumes are greater which provides some additional storage for larger events. Both facilities have 1 foot of freeboard. This volume is additional to the volume provided in the calculations.	Drawdown Time = Depth of Facility / Design Infiltration Rate = 2.3 ft. x 12 in. / 0.5 in/hr = 55.2 hrs	Drawdown Time = Depth of Facility / Design Infiltration Rate = 1.8 ft. x 12 in. / 0.5 in/hr = 43.2 hrs	Drawdown Time = Depth of Facility / Design Infiltration Rate = = N/A
	Loading Ratio = Impervious Area Controlled : Area of Facility = 5,000 sq. ft. : 500 sq. ft. = 10:1	Loading Ratio = Impervious Area Controlled : Area of Facility = 3,000 sq. ft. : 300 sq. ft. = 10:1	Loading Ratio = Impervious Area Controlled : Area of Facility = N/A
	Existing Discharge Point (Inlet/Sewer/Stream): Stream	Existing Discharge Point (Inlet/Sewer/Stream): Inlet/Sewer System	Existing Discharge Point (Inlet/Sewer/Stream): N/A
	Discharge Method for Runoff in Excess of 2": Spillway Capacity**: 50 cfs	Discharge Method for Runoff in Excess of 2": Orifice Outlet Capacity**: 77 cfs	Discharge Method for Runoff in Excess of 2": N/A Capacity**: N/A
*Infiltration facilities with stone beds: 40% void space, multiply volume in stone portion by 0.4. Calculations: Facility #1 has 1 ft. of stone: 500 ft ² x 1 ft. stone x 0.4 = 200 ft ³ in stone portion; Volume = 500 ft ³ stone + (833 - 200) = 1,133 cu. ft. Depth = 1 ft. stone + (833 - 200) / 500 ft ² = 1 ft. + 1.3 ft = 2.3 ft. Facility #2 has ½ ft. of stone: 300 ft ² x ½ ft. stone x 0.4 = 60 ft ³ in stone portion; Volume = 150 ft ³ stone + (500 - 60) = 590 cu. ft. Depth = ½ ft. stone + (500 - 60) / 300 sq. ft. = ½ ft. + 1.3 ft. = 1.8 ft.			
**If a grass spillway is used: Capacity (cfs) = 2.5 x Length x Freeboard^{1.5} **If an orifice structure is used: Capacity (cfs) = 0.6 x Orifice Area x (2 x 32.2 x Flow Depth Above Orifice)^{0.5} Capacity Calculations: Facility #1 spillway: Capacity = 2.5 x (20 ft.) x (1 ft.) ^{1.5} = 50 cfs			

Facility #2 orifice outlet: Use 1 ft. high by 2 ft. wide orifice; Capacity = $0.6 \times (2 \text{ ft}^2) \times (2 \times 32.2 \times 1)^{0.5} = 77 \text{ cfs}$

Project Sketch

APPENDIX E

STORMWATER MANAGEMENT FOR SMALL PROJECTS

Applicability: Stormwater management procedures for projects between 1,000 sq. ft. and 5,000 sq. ft. of proposed impervious area or total earth disturbance between 5,000 sq. ft. and 10,000 sq. ft. for which site conditions prevent the use of Ordinance Appendix C.1 - Disconnected Impervious Area (DIA) as a BMP.

Note: This small projects document is not to be used to plan for multiple lots without obtaining prior written approval from the City. Approvals and actions associated with this document do not relieve the applicant of the responsibility to secure required permits or approvals for activities regulated by any other code, law or ordinance.

E.1 Introduction

These methods have been developed to allow homeowners to comply with stormwater management criteria for new projects to meet the requirements of the Act 167 Stormwater Management Ordinance of the City including sizing, designing, locating, and installing on-lot measures, referred to herein as “Best Management Practices” (BMPs). Pennsylvania Act 167 was authorized on October 4, 1978 (32 P.S., P.L. 864) and gave Pennsylvania municipalities the power to regulate activities that affect stormwater runoff and surface and groundwater quantity and quality.

Individual home construction projects on single-family lots which result in 1,000 sq. ft. to 5,000 sq. ft. of proposed impervious area (including the building footprint, driveway, sidewalks, and parking areas) are not required to submit formal stormwater management (SWM) site plans to the City or County; however, they must address water quality and infiltration goals, and submit the worksheet as outlined in this small projects document. If the guidelines presented in this brochure are followed, the individual homeowner will not require professional services to comply with these water quality and infiltration goals.

Section E.2 presents options of BMPs that can be considered for on-lot stormwater management. Section E.3 describes requirements and outlines the method for designing a suitable BMP, and a description of what needs to be included on the simple sketch plan, and the Small Projects Worksheet in Table E.4. Section E.4 contains an example of how to obtain the size and dimensions of the BMPs, complete the site sketch, and prepare the Small Project Worksheet.

The stormwater management method for small projects requires:

- The first 1” of rainfall runoff from proposed impervious surfaces to be captured (see definition of captured in Article II of the Ordinance).

The purpose of this small projects document is to help reduce stormwater runoff in the community, to maintain groundwater recharge, to prevent degradation of surface and groundwater quality, and to otherwise protect water resources and public safety.

What needs to be sent to the City?

Stormwater computations and a sketch plan must be submitted to the City. The small projects worksheet found in Table E.4 and a simple sketch plan containing the features described in Step 5 of Section E.3 is provided as an example, or may be used for submission to the City, and if applicable, the contractor prior to construction.

E.2 Description of BMPs

The following is a description of several types of BMPs that could be implemented. Refer to Chapter 6 of the PA BMP Manual which can be found on the PA Department of Environmental Protection's website for specifications and steps for construction for the following BMPs. A list of routine maintenance for each of the BMPs described below is also included at the end of this section.

Rain Barrels/Cisterns

- Rain barrels and cisterns are large containers that collect drainage from roof leaders and temporarily store water to be released to lawns, gardens, and other landscaped areas; rain barrels are typically less than 50 gallons in size, and cisterns typically have volumes of up to 1,000 gallons or more, and can be placed on the surface or underground.

Figure E.1. Rain Barrels.



Source (left): <http://www.rfcity.org/Eng/Stormwater/YourProperty/YourProperty.htm>

Source (right): <http://www.floridata.com/tracks/transplantedgardener/Rainbarrels.cfm>

Figure E.2. Cisterns.



Source: Pennsylvania Stormwater Best Management Practices Manual.

Rain Garden/Bioretention Area

- A rain garden/bioretention area is an excavated depression area on the surface of the land in which native vegetation is planted to filter and use stormwater runoff; depths of 1.0 foot or less are recommended. Planting species should be native to Pennsylvania.

Figure E.3. Typical Rain Garden/Bioretention Area.

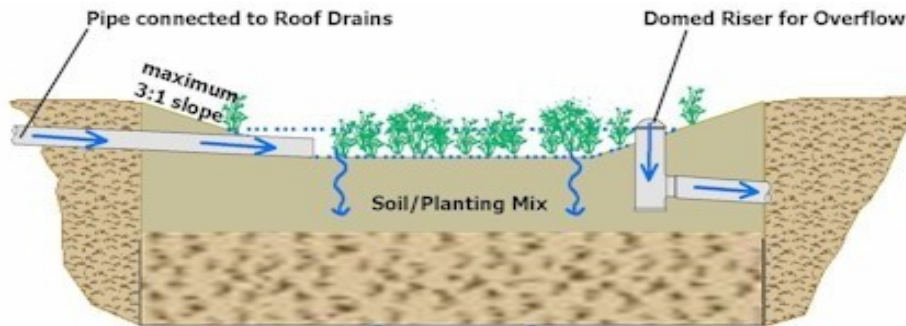

Source: Pennsylvania Stormwater Best Management Practices Manual.

Table E.1. Sample Plant List for Use in a Rain Garden/Bioretention Area.

Common Name	Scientific Name	Plant Type
Red Maple	<i>Acer rubrum</i>	Tree
Grey Birch	<i>Betula populifolia</i>	Tree
Shadbush Serviceberry	<i>Amelanchier canadensis</i>	Tree
Eastern Cotton-wood	<i>Populus grandidentata</i>	Tree
Virginia Sweetspire	<i>Itea virginica</i>	Shrub
Red-Twig Dogwood	<i>Cornus sericea (stolonifera) 'Arctic Fire'</i>	Shrub
Southern Arrow-wood	<i>Viburnum dentatum</i>	Shrub

Black Choke Berry	Aronia melanocarpa	Shrub
Great Blue Lobelia	Lobelia siphilitica	Perennial
Dwarf Pink false aster	Boltonia asteroides 'Nana'	Perennial
White false aster	Boltonia asteroides 'Snowbank'	Perennial
Switchgrass	Panicum virgatum	Grass

Source: Pennsylvania Stormwater Best Management Practices Manual.

Dry Wells

- A dry well, also referred to as a seepage pit is a subsurface storage facility that temporarily stores and infiltrates runoff from the roofs of buildings or other impervious surfaces; recommended depth of dry well is between 1.0 and 4.0 feet.
- Dry Well #1 – structural prefabricated chamber; no stone fill.
- Dry Well #2 – excavated pit filled with stone fill.

Figure E.4. Dry Well #1 – Structural Prefabricated Chamber.



Source: <http://www.copelandconcreteinc.net/1800652.html>

Figure E.5. Dry Well #2 – Excavated Pit Filled with Stone Fill.

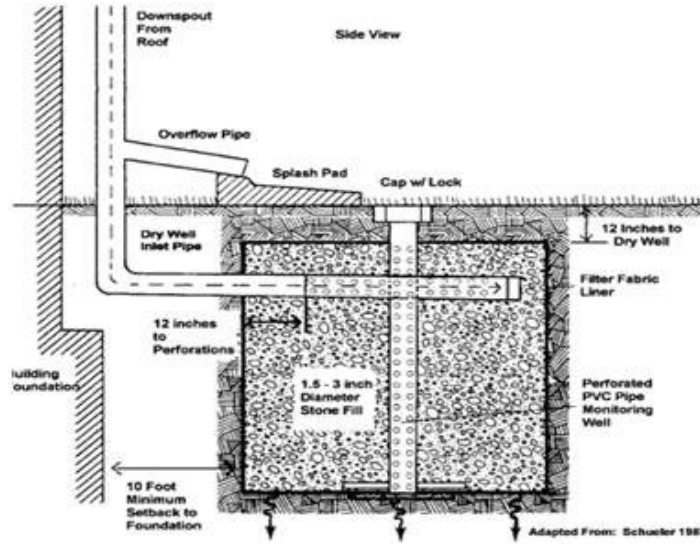

Source: <http://www.seagrant.sunysb.edu/pages/BMPsForMarinas.htm>

Infiltration Trench

- An infiltration trench is a long, narrow, rock-filled trench with or without a perforated pipe that receives stormwater runoff and has no outlet.
- Runoff is stored in the void space between the stones and in the pipe and infiltrates through the bottom and into the underlying soil matrix.
- The width is limited to between 3 and 8 feet, and the depth ranges from 2 to 5 feet.

Figure E.6. Infiltration Trench.

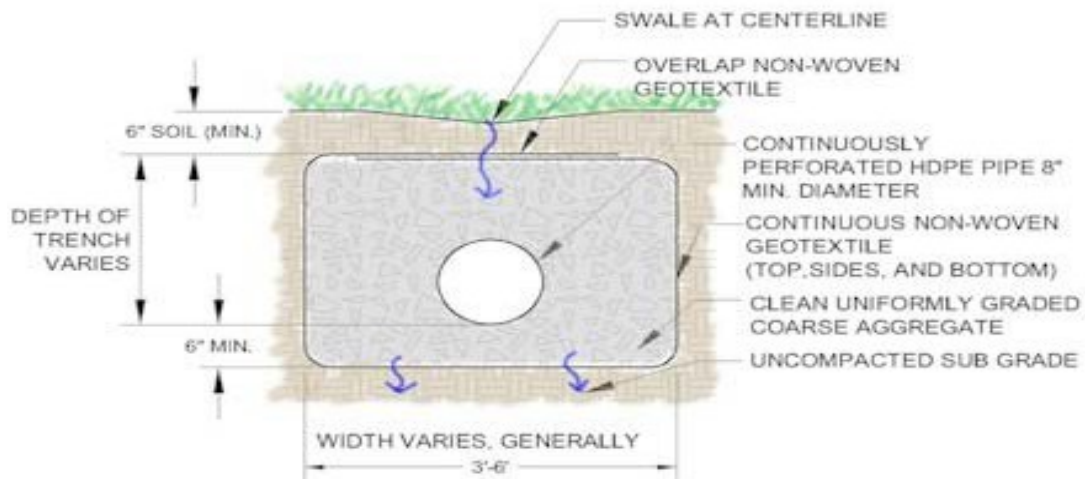

Source: Pennsylvania Stormwater Best Management Practices Manual.

Routine Maintenance for BMPs

- Vegetation along the surface of an infiltration trench should be maintained in good condition, and any bare spots should be revegetated as soon as possible.
- Vehicles shouldn't be parked or driven on an infiltration trench, and care should be taken to avoid excessive compaction by mowers.
- Any debris such as leaves blocking flow from reaching an infiltration trench or bioretention/rain garden should be routinely removed.
- While vegetation is being established, pruning and weeding may be required for a bioretention/rain garden.
- Mulch in a bioretention/rain garden needs to be re-spread when erosion is evident. Once every two to three years or after major storms the entire area may require mulch replacement.
- At least twice a year the landowner needs to inspect the bioretention/rain garden for sediment buildup and vegetative conditions.
- During periods of extended drought, the bioretention/rain garden requires watering.
- Trees and shrubs in a bioretention/rain garden need to be inspected at least twice per year by the landowner to evaluate their health. If they are in poor health, they need to be replaced.
- Dry wells need to be inspected by the landowner at least four times a year and after significant rainfalls, and debris/trash, sediment, and any other waste material need to be removed and disposed of at suitable disposal/recycling sites and in compliance with local, state, and federal waste regulations.
- For dry wells, gutters need to be regularly cleaned out, and proper connections must be maintained to facilitate the effectiveness of the dry well.
- The filter screen for the dry well that intercepts roof runoff must be replaced as necessary.
- Dry wells that are damaged need to be fixed or replaced immediately.
- If an intermediate sump box exists in conjunction with a dry well, it must be cleaned out at least once per year.
- Rain barrels and cisterns need to be cleared of debris routinely at least every three months and after significant storms to allow stormwater from gutters to enter them.
- Gutters that directly convey rain water to dry wells, rain barrels, and cisterns need to be routinely cleared of trash and debris at least every three months and after significant storms.
- Rain barrels and cisterns must be kept covered.
- Rain barrels and cisterns should be routinely emptied so that they are only $\frac{1}{4}$ of the way full to allow for storage of additional rainwater.
- Overflow outlets from rain barrels and cisterns must be kept free and clear of debris.
- Rain barrels and cisterns that are damaged need to be fixed or replaced immediately.

E.3. Determination of BMPs and Volume Requirements

All proposed impervious areas must be included in the determination of the amount of new impervious areas and the size of proposed BMPs needed to control stormwater.

Proposed impervious areas on an individual residential lot include:

- Roof area
- Pavement
- Sidewalks
- Driveways
- Patios
- Porches
- Permanent pools
- Parking areas

Sidewalks, driveways, or patios that are constructed with gravel or pervious pavers that will not be converted to an impervious surface in the future need not be included in this calculation. Therefore, the amount of proposed impervious area can be reduced for proposed driveways, patios, and sidewalks through the use of gravel, pervious pavement, and turf pavers. All proposed impervious areas must be constructed so that runoff is conveyed to a BMP; no runoff can be directed to storm sewers, inlets, or other impervious areas (i.e., street).

All new construction should incorporate design techniques that include: minimizing the amount of land disturbance, reducing impervious cover, disconnecting gutters and directing runoff to vegetated areas to infiltrate, and redirecting the flow of runoff from impervious driveways to vegetated areas instead of to the street or gutter.

Below are the steps that must be undertaken to meet the Ordinance requirements. The results obtained for each step must be included in the Small Projects Worksheet found in Table E-4:

STEP 1 – Determine the total area of all proposed impervious surfaces (square feet) that will need to drain to one or more BMPs.

STEP 2 – Determine locations where BMPs need to be placed, and the contributing impervious area “*I*” (square feet) to each.

STEP 3 – Select the BMPs to be used and determine the requirements of each from Section E.3.

STEP 4 – Obtain the required storage volume “*V*” (cubic feet) and surface area “*A*” (square feet) needed for each of the proposed BMPs from the appropriate heading below.

Note: all calculations are based on 1 inch of rainfall.

For Rain Barrels/Cisterns

- The typical volume of a rain barrel is less than 50 gallons; if a greater volume is required, more than one rain barrel will be needed or a cistern may be used.
- For calculations, assume the rain barrel is already 25% full.
- Calculate volume in Cubic Feet:

$$V_{cf} = (1 \text{ inch} \times 1/12 \times I) / 0.75$$

- Convert to Gallons:

$$V_{gal} = V_{cf} \times 7.48$$

For Rain Gardens/Bioretenion or Dry Well #1:

- Rain gardens and bioretention areas are only used for depths less than or equal to 1.0 feet; a dry well #1 is used for depths between 1.0 and 4.0 feet.
- Select the depth “**D**” (feet) for the facility.
- For calculations, assume the facility is empty (0% full).
- Calculate volume in Cubic Feet:

$$V_{cf} = (1 \text{ inch} \times 1/12 \times I)$$

- Calculate surface area of the facility in Square Feet:

$$A_{sf} = V_{cf} / D$$

For Dry Well #2 or Infiltration Trench:

- A dry well #2 is used for depths between 1.5 feet and 4.0 feet; an infiltration trench is used for depths between 2.0 and 5.0 feet.
- Select the depth “**D**” (feet) for the facility.
- For calculations, assume the void ratio of the stone is 40%.
- Calculate volume in Cubic Feet:

$$V_{cf} = (1 \text{ inch} \times 1/12 \times I) / 0.4$$

- Calculate surface area of the facility in Square Feet:

$$A_{sf} = V_{cf} / D$$

- Determine the dimensions of the facility based on “**A**” calculated.

STEP 5 - Sketch a simple site plan that includes:

- Name and address of the owner of the property, and or name and address of the individual preparing the plan, along with the date of submission.
- Location of proposed structures, driveways, or other paved areas with approximate size in square feet.
- Location, orientation, and dimensions of all proposed BMPs. For all rain gardens/bioretention, infiltration trenches, and dry wells, the length, width, and depth must be included on the plan. For rain barrels or cisterns the volume must be included.
- Location of any existing or proposed on-site septic system and/or potable water wells showing rough proximity to infiltration facilities.
- Location of any existing waterbodies such as; streams, lakes, ponds, wetlands, or other waters of the Commonwealth within 100 feet of the project site, and the distance to the project site and/or BMPs. It is recommended that the project or BMPs be located at least than fifty (50) feet away from a perennial or intermittent stream. If an existing buffer is legally prescribed (i.e., deed, covenant, easement, etc.), the existing buffer shall be maintained.
- Location of all existing structures including buildings, driveways, and roads within fifty (50) feet of the project site.

Fill in the small projects worksheet found in Table E.4, then submit the worksheet and the simple site sketch (or equivalent) to the City.

Table E.4. Small Projects Worksheet.

E.4. Example

Joe Homeowner wants to build an 800 sq. ft. two car garage, and a 700 sq. ft. impervious driveway. Site conditions in the urban setting prevent the use of Disconnected Impervious Area (DIA) as a BMP.

STEP 1 – Determine the total area of all proposed impervious surfaces that will need to drain to one or more BMPs.

- Garage roof: 20 ft. x 40 ft. = 800 sq. ft.
- Driveway: 50 ft. x 14 ft. = 700 sq. ft.
- Total proposed impervious surface = 800 + 700 = **1,500 sq. ft.**

STEP 2 – Determine locations where BMPs need to be placed, and the contributing impervious area “*I*” to each.

- Use BMP #1 to capture runoff from the garage ($I_1 = 800$ sq. ft.)
- Use BMP #2 to capture runoff from the driveway ($I_2 = 700$ sq. ft.).

STEP 3 – Select the BMPs to be used and determine the requirements of each from Section E.3.

- BMP #1 – rain barrel/cistern
- BMP #2 – infiltration trench

STEP 4 – Obtain the required storage volume “*V*” and surface area “*A*” needed for each of the proposed BMPs from the appropriate heading below.

For Rain Barrel/Cistern (BMP #1)

- Calculate volume in cubic feet:

$$\begin{aligned}V_{cf} &= (1 \text{ inch} \times 1/12 \times I_1) / 0.75 \\ &= (1 \text{ inch} \times 1/12 \times 800) / 0.75 \\ &= \mathbf{88.89 \text{ cubic feet}}\end{aligned}$$

- Convert to gallons:

$$\begin{aligned}V_{gal} &= V_{cf} \times 7.48 \\ &= \mathbf{88.89 \times 7.48} \\ &= \mathbf{664.8 \text{ gallons}} \diamond \text{ round up to } \mathbf{665 \text{ gallons}}\end{aligned}$$

For Infiltration Trench (BMP #2)

- Select depth “**D**” for the facility of **2 feet** (between 2.0 feet and 5.0 feet).
- Calculate volume in cubic feet:

$$\begin{aligned}V_{cf} &= (1 \text{ inch} \times 1/12 \times I_2) / 0.4 \\ &= (1 \text{ inch} \times 1/12 \times 700) / 0.4 \\ &= 145.8 \text{ cubic feet} \diamond \text{ round up to } 150 \text{ cubic feet}\end{aligned}$$

- Calculate surface area of the facility in square feet:

$$\begin{aligned}A_{sf} &= V_{cf} / D \\ &= 150 / 2 \\ &= 75 \text{ square feet}\end{aligned}$$

- The driveway is 50 feet long, so using the upper 30 feet of the driveway as the length of the infiltration trench, the width of the trench =

$$75 \text{ square feet} / 30 \text{ feet} = 2.5 \text{ feet}$$

- Use a **2.5 ft. wide x 30 ft. long x 2 ft. deep** infiltration trench.

STEP 5 – Prepare a simple site sketch (Figure E.7) and complete Small Projects Worksheet (Table E.4) to send to City of Hazleton Engineer’s Office.

Figure E.7. Simple Site Sketch of Proposed Project and Proposed BMPs.

Table E.4. Small Projects Worksheet.

APPENDIX F.1

STORMWATER MANAGEMENT DISTRICT MAPS

APPENDIX F.2

HYDROLOGIC SOIL GROUP (HSG) MAP

ORDAINED AND ENACTED by the Council of the City of Hazleton, this 8th day of February, 2022.